



- **Displays Tank Level at the Deck Filler and at the existing instruments**
- **Prevents fuel spills during refuelling**
- **Maximise Range from Full Tanks**
- **Available for “FUEL”, “DIESEL”, “GAS” or “WATER”**
- **Fits 50mm/2” or 38mm/1.5” pipes**
- **Blue LED Level Display**
- **Robust Stainless Steel with Laser Etched designator**
- **Easy to Install**
- **Single Plug to NMEA2000® Bus**



**Registered Design**  
**International Patents Pending**



## **Deck Filler Gauge** **for NMEA2000® Senders**



The 3210 NMEA2000® Deck Filler Gauge displays the tank level right at the tank's deck filler.

This enables the user to see the exact tank level at the point of filling. This allows the tanks to be filled to the top without the risk of spills or wastage.

The tank level is displayed on a blue LED display set into the deck filler surround. This provides a clear indication of the level of the liquid in the tank at all times. The LED varies in brightness to compensate for ambient light levels, brighter in sunlight and dimmer at night.

The deck filler cap has a standard octagonal opening key with a heavy duty O ring seal to keep sea water out of the tank. The deck filler and it's cap are produced in mirror polished stainless steel to provide a rugged and attractive finish.

It is constructed to the IEC60945 Maritime Navigational and Radiocommunications Equipment Standard to ensure high reliability and trouble free operation for many years.

It is NMEA2000® Certified and attaches to the network using a single plug. No other wiring is needed.

# NMEA2000® Sender Deck Filler Gauge

## Part No: 3210-D (Diesel) -F (Fuel) -G (Gas) -W (Water)

### Dimensions

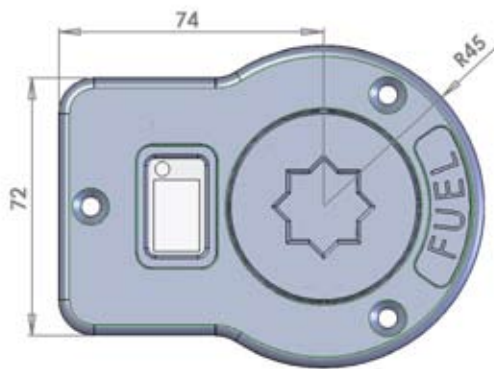

### Typical Installation

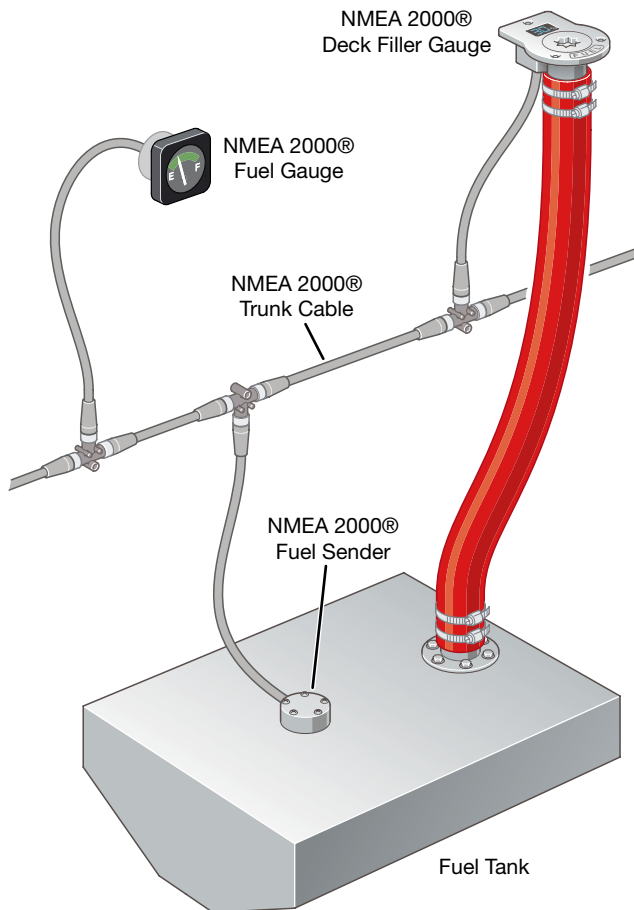

Specification	
Display Accuracy	Displays to 1%
Tank Contents	Fuel or Water
Tank Instances	Up to 16 tank instances on network
Certification	
NMEA2000	Certified Level B+
NMEA PGNs	
Received	PGN 059904 ISO Request PGN 060928 Address Claim PGN 127505 Fluid Level
Transmitted	PGN 059392 Acknowledgement PGN 060928 Address Claim PGN 126996 Product Information
Electrical	
Operating Voltage	9 - 16 Volts DC from NMEA network
Connector	Micro plug on 1 metre cable
Power	Less than 150mA
Load Equivalence	3 LEN according to NMEA2000 spec
Reverse Battery	Fully protected indefinitely
Mechanical	
Pipe Size	50 mm/ 2" or 38mm/1.5" ID
Weight	700 grams
Environmental	
IEC Classification	Exposed
Protection	IP68
Operating Temp	-20°C to 50°C
Storage Temp	-50°C to 70°C
Relative Humidity	93% RH @ 40°C per IEC60945-8.2
Vibration	2-13.2Hz @ ±1mm, 13.2-100Hz @ 7m/s <sup>2</sup> per IEC 60945-8.7
EMC Emission	Conducted & Radiated per IEC60945-9
EMC Immunity	Conducted, radiated, supply and ESD per IEC60945-10



The inclusion of vessels in any picture does not infer that their manufacturer endorses this product. Our policy is one of continuous product improvement so product specifications are subject to change without notice. Our products are designed to be accurate and reliable, however, they should only be used as aids to the safe management of the boat and not as a replacement for traditional aids or techniques.  
Copyright © 2009 Offshore Systems (UK) Ltd. All rights reserved.

**Offshore Systems (UK) Ltd**  
 Unit 11 Milton Business Centre, Wick Drive,  
 New Milton, Hampshire, BH25 6RH, United Kingdom  
 Tel: +44(0)1425 610022 Fax: +44(0)1425 614794  
 Email: mail@osukl.com Web: www.osukl.com