



Resistive Sender Deck Filler Gauge

Part Numbers:-

2210-D38 & -D50 Fuel Deck Filler Gauge

2210-F38 & -F50 Fuel Deck Filler Gauge

2210-W38 & -W50 Water Deck Filler Gauge

Introduction

The 2210 Deck Filler Gauge is designed to display the fuel or water level in the tank being filled right at the point of filling. It is available for either fuel or fresh water and for either 38mm or 50mm filler pipe sizes:

The 2210-F38 or 2210-F50 Fuel Deck Filler Gauge displays the level of fuel in the tank connected to the deck filler.

The 2210-W38 or 2210-W50 Water Deck Filler Gauge displays the level of water in the tank connected to the deck filler.

Safety Instructions

This Deck Filler Gauge should only be installed by a person competent and experienced in working with fuel and water systems on board vessels.

All work involving fuel systems should be performed with extreme care due to the possibility of igniting fuel fumes.

Before beginning work the battery should be disconnected to avoid the risk of a short circuit, a fire or an explosion.

Before drilling any holes to mount the unit or run the cabling always make sure it is safe to do so.

Location and installation

The Deck Filler Gauge will be mounted either through the deck of the vessel or in a recess that is easily accessible for filling the tank. The white neoprene deck gasket supplied with the unit can be used to mark the cutout and mounting holes needed to mount the unit, Simply place the gasket in the desired location and mark the cutout and mounting holes with a pencil to show where to cut and drill. Take care to choose a location that is accessible below deck to allow the secure connection of the tank filling hose and the signal cable.

Carefully cut around the mounting hole marked on the deck and drill the mounting screw holes. Then place the gasket on the deck and thread the signal cable and the Deck Filler body through the gasket and secure it to the deck using the mounting screw holes. The neoprene gasket should provide a watertight seal between the Deck Filler Gauge and the deck but if it is mounted in an exposed location use of an additional suitable deck sealant would be advised.

It is **very important** that the Fuel Deck Filler Gauge body should be **securely electrically bonded to the Tank and the ships ground** with a strong electrical bonding wire as recommended by the boat wiring regulations in your region. The signal cable is **NOT** electrically connected to the Fuel Deck Filler body and cannot achieve this electrical bond.

Attach the filler pipe to the Deck Filler gauge securely. We recommend the use of two separate hose clips to ensure that this joint is secure.

Wiring

The Deck Filler Gauge signal cable should be routed to the Panel Gauge for the tank. This cable should be secured at regular intervals to prevent any damage following recognised boat wiring principles.

The wires within the signal cable should be connected as follows for a single Deck Filler Gauge installation:

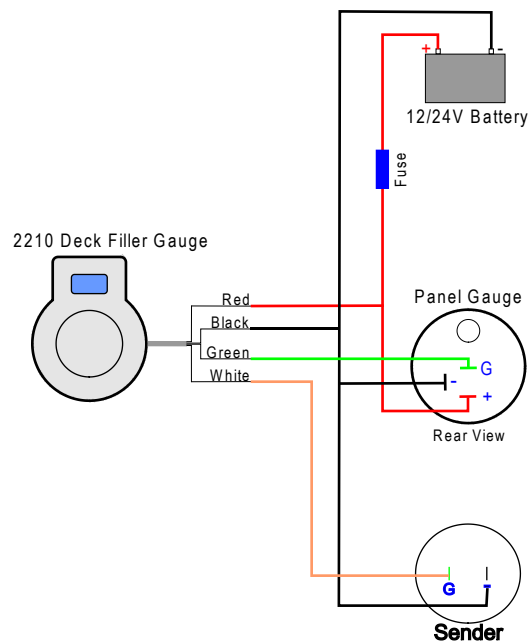

Figure 1. Single Deck Filler Gauge with normal power.

When the Deck Filler Gauge power has to be isolated from the main power system of the boat, the power to the panel gauge must be on the same circuit. The Panel Gauge must be powered when the Deck Filler Gauge is powered or the Deck Filler Gauge will not work.

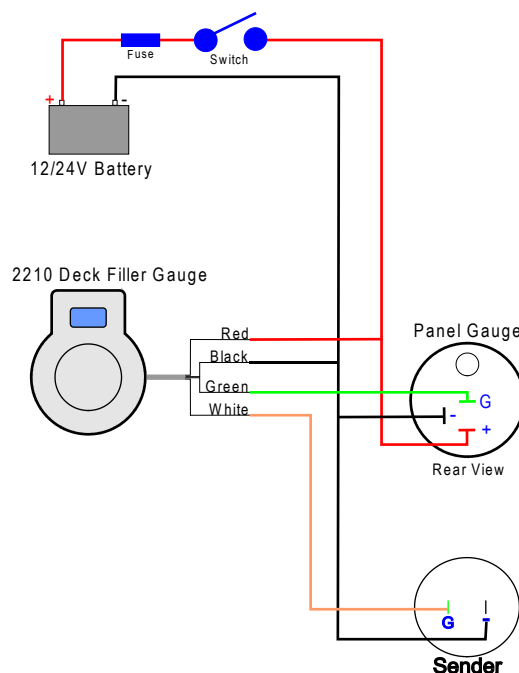

Figure 2. Single Deck Filler Gauge with Isolated Power

It is possible to connect two Deck Filler Gauges to the same Panel Gauge and Sender if there are two filling points to the same tank. This is done as follows:

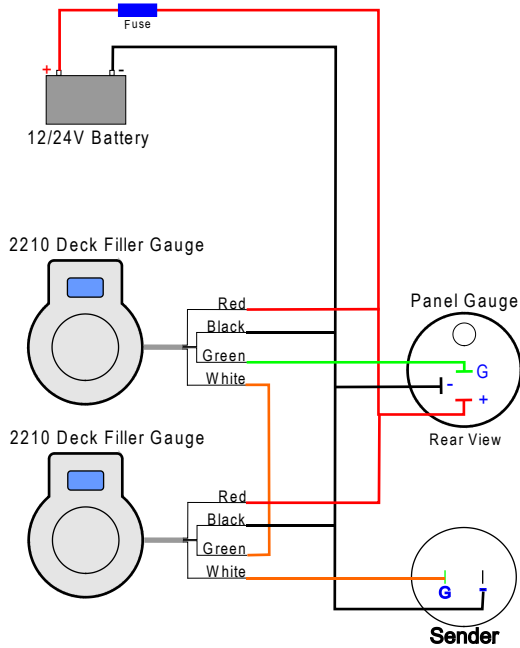

Figure 3. Dual Deck Filler Gauges

Calibration before use

The Deck Filler Gauge needs to be calibrated to the sender and gauge it is connected to. This is an easy two stage process that can be completed in a couple of minutes.

When the unit is first powered on it will display “cc” meaning that it requires the calibration to be done.

With the unit powered on and the tank sender in it’s empty position simply touch the small calibration magnet to the underside of the unit in the area marked “Magnet Cal. Empty”. The display will then show “c_” meaning that the empty calibration has been done but the full calibration has yet to be done.

With the sender in the full position simply touch the small calibration magnet to the underside of the unit in the area marked “Magnet Cal. Full”. This can be done with either a full tank or by holding the sender into the position it would be in with a full tank.

These calibrations can be done in either order.

When both calibrations are done the unit will display the percentage level of the tank from 0% up to “FF” when the tank is full.

Operation

Once the module has been installed there is no normal operator intervention required. The unit should be washed occasionally to remove any salt buildup. The use of a pressure washer is not recommended.

Display

The LED display will show tank levels from 0% to 99% as the numbers 0 to 99. When the tank is at 100% the display will show “FF”.

The LED display will vary in brightness according to the ambient light level. When it is dark the display is dimmed rising to full brightness in direct sun.

Accuracy

The Deck Filler Gauge is accurate to +/- 2% but the overall system accuracy is limited by the resistive sender and existing gauge which can both be fairly inaccurate. These inaccuracies will reflect in the value shown in the digital display and the user should allow for these inaccuracies when interpreting the display.

Warranty

Offshore Systems (UK) Ltd warrants goods of its manufacture as being free of defective materials and faulty workmanship. Contact Offshore Systems (UK) Ltd for full warranty information. If warranted goods are returned to Offshore Systems (UK) Ltd during the period of coverage, Offshore Systems (UK) Ltd will repair or replace without charge those items it finds defective. The foregoing is the Buyer’s sole remedy and is in lieu of all other warranties, expressed or implied, including those of merchantability and fitness for a particular purpose.

Specifications may change without notice. The information we supply is believed to be accurate and reliable as of this printing. However we assume no responsibility for its use

Offshore Systems (UK) Ltd

2 Lower Ashley Road, New Milton,
Hampshire, BH25 5AD, UK

Tel: +44 (0)1425 610022 Fax: +44 (0)1425 614794

Web: www.osukl.com Email: mail@osukl.com